

TANDEM VIBRATORY COMPACTOR

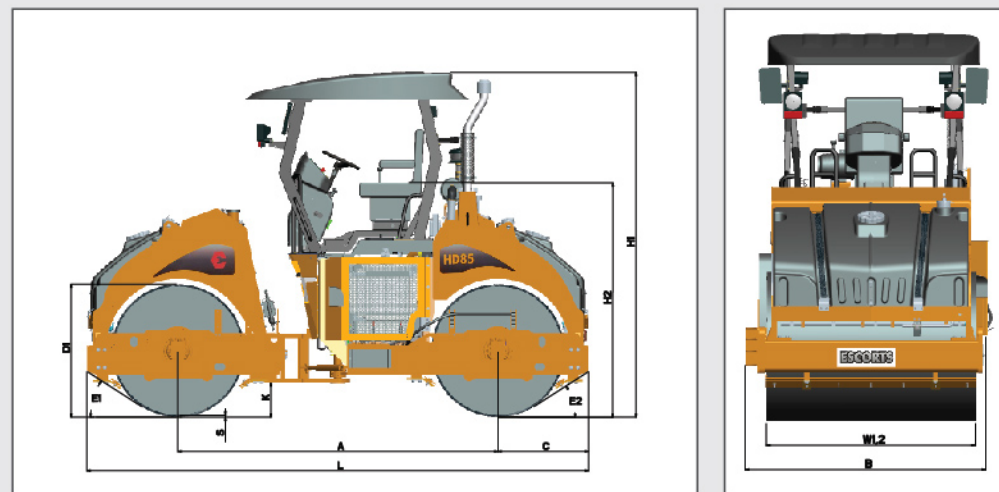

STATIC DIMENSIONS		
A	Wheel Base	2900 mm
B	Overall Width	1922 mm
C	Axle To Rear Face	820 mm
D1=D2	Drum Diameter	1200 mm
H1	Total Travel Clearance With Canopy	3125 mm
K	Ground Clearance	310 mm
L	Total Travel Length	4550 mm
O	Overhang	170 mm
S	Drum Thickness	17 mm
W1=W2	Drum Width	1680 mm
E1	Front Departure Angle	31°
E2	Rear Departure Angle	31°



Plot No.- 219, Sector-58, Ballabhgarh- 121 004  
 Distt.- Faridabad, Haryana (INDIA)  
 Tel.- +91-129- 2306574/2306598/2306571 Fax- +91-129- 2306572  
 Toll Free No.- 1800- 180- 4488 (Timings: 9.30 am - 6.00 pm, Monday to Friday)  
 E-mail- ece.marketing@escorts.co.in Website- www.escortsgroup.com

Accessories shown in the picture may not be the part of standard fitment and are subject to change without prior notice.

The information contained in this folder is intended to be of general nature only. We reserve the right to change specifications without notice.



**Compactor**  
 • ROLL 'n ROCK •



# ESCORTS ADVANTAGE

# TECHNICAL SPECIFICATIONS

## OPERATIONAL PARAMETERS



- Amplitude  
High - 1.0 mm  
Low - 0.4 mm
- Frequency  
33 Hz  
50 Hz
- Delay relay to avoid the sudden impact while switching from one frequency to another

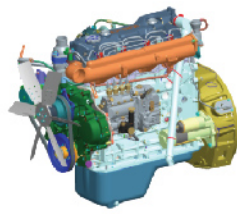

## ENGINE

- 75 HP BS III CEV compliant 4 Cylinder water cooles turbo charged ESCORTS E4.286 engine with inline pump
- Best-in-class fuel economy
- High on performance
- Lowest maintenance cost in its class

## HIGH GRADEABILITY

- Equipped with ESCORTS engine, the ESCORTS tandem series can compact in steep terrain up to a max of 45% (without vibration)

## STURDY AND RELIABLE CONTROLS



- Dust & weather proof, rocker switch for high reliability
- IP 65 Compliant Instrument cluster from front side
- IP 67 Compliant Rocker switches

## THE EASE OF MAINTENANCE

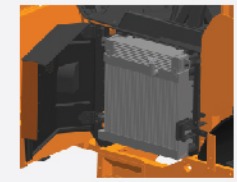

- Combi-cooler side by side, ease of serviceability like cleaning



## STATE-OF-THE-ART SPRINKLING SYSTEM

- Sprinkling nozzles with four stage filtration to avoid clogging
- Tongue-type nozzles to avoid rusting
- Wide flat fan with a sharply delimited spray pattern for long last uses

## OPERATOR PLATFORM - THE DEFINITIVE STATEMENT

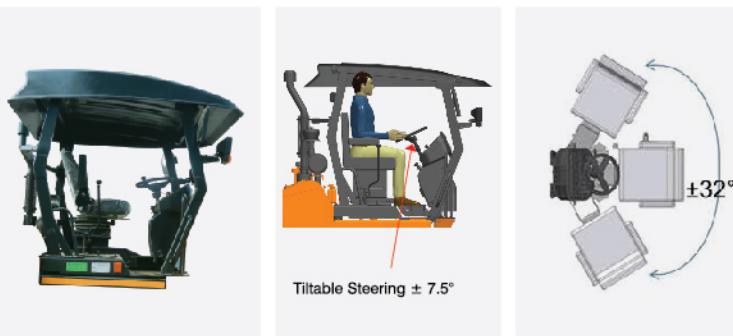

- FRP canopy & ergonomically designed space for operator comfort
- Operator platform with bolt on legs for ease of transportation
- Rotating Platform  $\pm 32^\circ$

## ELECTRICALS



- Heavy duty, maintenance free battery at convenient location - 180 Ahr

PARAMETERS	UNIT	HD 85
<b>WEIGHTS</b>		
Maximum Operating Weight	kg	9300
Operating Weight	kg	9000
Weight On Front Drum	kg	4500
Weight on Rear Drum	kg	4500
Static Liner Load-Front	kg/cm	26.8
Static Liner Load-Rear	kg/cm	26.8
<b>ENGINE</b>		
Make		ESCORTS E4.286
Type		4 Cylinder, Water Cooled, BS III (CEV) Emission Norms
Rated power		75 HP @ 2300 RPM
Electrical System		12V
<b>VIBRATION SYSTEM</b>		
Frequency	Hz	33/50
High Amplitude	mm	1.0
Low Amplitude	mm	0.4
<b>SPEED</b>		
Travelling Speed	km/hr	0-9.5
<b>GRADEABILITY</b>		
Gradeability Without Vibration	%	45
Gradeability With Vibration	%	30
<b>STEERING</b> <span style="float: right;">Hydrostatic Power Steering</span>		
Steering Angle	Deg	$\pm 30$
Oscillation Angle	Deg	$\pm 10$
Turning Radius-outer/inner	mm	6200/4550
<b>BRAKES</b>		
Service Break		Hydrostatic
Parking Brake, Emergency Stop		Spring Loaded Brake, Hydraulically released on both drums
<b>CAPACITY</b>		
Water Tank	Ltr	700
Fuel Tank	Ltr	140
Hydraulic Oil Tank	Ltr	80
<b>STANDARD EQUIPMENT</b>		
Swinging Operator Seat for better drum visibility, Tilttable Steering, Larger Operator Platform accessible from each side, Electric Operator Controls, FRP Roof, Instrument Panel with a range of control instruments including Hour Meter & Light Equipment, Neutral & Parking ON Indicator, RPM Gauge.		
<b>SAFETY FEATURES</b>		
Neutral Start Safety, Emergency Brake Switch, Reverse Alarm, Air Filter Clog Indicator, Hydraulic Filter Clog Indicator, Low Engine Oil Pressure Indicator & Alarm, Hydraulic Oil Temperature Gauge, Battery Not Charging Indicator, Starter Safety Relay, Coolant Temperature Gauge & Indicator, Vibration Cutoff at Neutral & Parking Brake Active Condition, Over & Long Cranking Protection, Auto-Vibration & Sprinkle Cut Off, Audio Visual Warning for High Coolant Temperature.		
<b>SPRINKLER SYSTEM</b>		
4 Stage Filtration Pressure Sprinkle, Foot Actuation (Manual), Interval (Automatic), Corrosion free Plastic Water Tank on each drum.		
<b>OPTIONAL FITMENT</b>		
Switchable to Single/ Either Drum Vibration, Cabin, Heater, Demister, Edge Cutting and Pressing Discs, Cold Start Kit, Intelligent Compaction System (ICS).		
<b>NOTE:</b> Technical modifications reserved. All Dimensions & Weights are variable within $\pm 2.5\%$ over Indicated Values.		